

Aluminium Profile



SHELVING DYNAMIC SYSTEM



2026

e-mail: sales@aluminium-profile.gr

www.aluminium-profile.gr

ΚΑΤΑΛΟΓΟΣ





Applications



Dynamic Aluminium Profiles



Connection Elements



Accessories

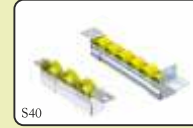
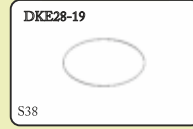

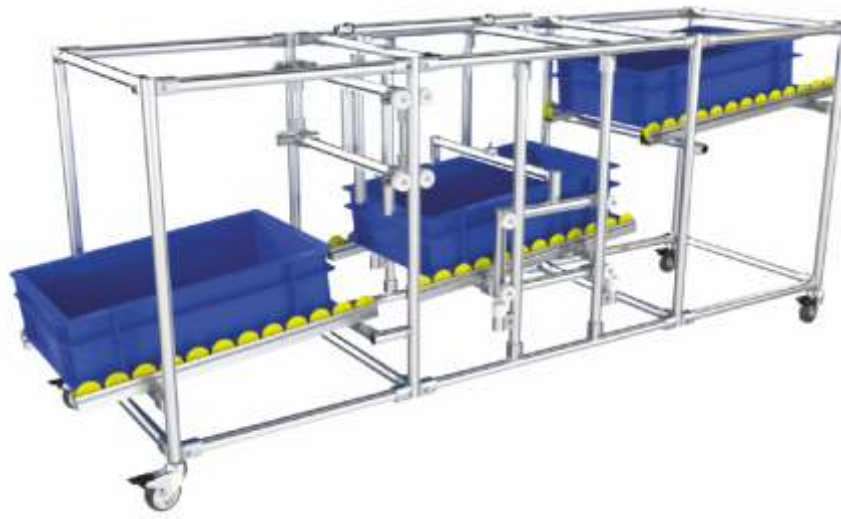









Ø28-1,7 mm Pipe Profile

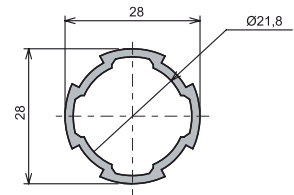
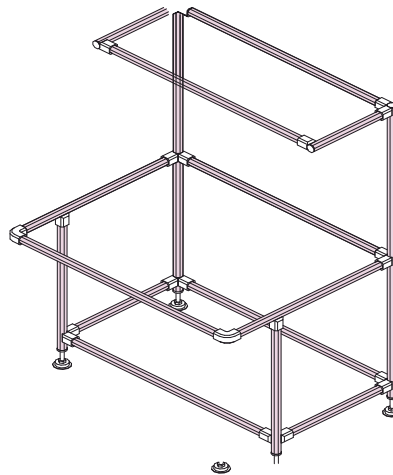

Code	Material	Moment of Inertia		Moment of Resistance		Area	Weight	
		I_x	I_y	W_x	W_y			
DK28-01A	6063	1.16cm^4	1.16cm^4	0.83cm^3	0.83cm^3	1.46cm^2	0.54 Kg/m	

Standart : 6000 mm

Ø28 Channel Profile

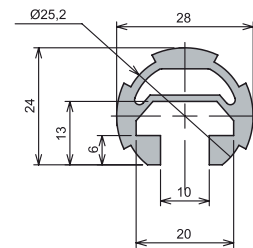
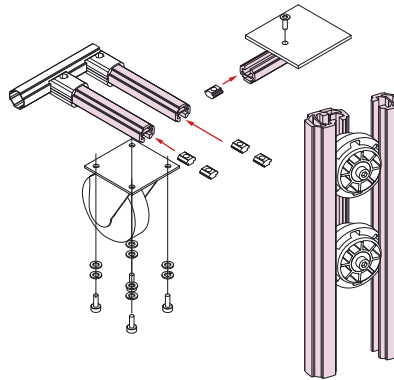
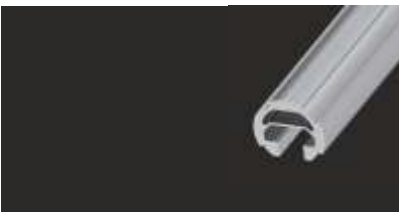

Code	Material	Moment of Inertia		Moment of Resistance		Area	Weight	
		I_x	I_y	W_x	W_y			
DK28-02A	6063	1.13cm^4	1.87cm^4	0.08cm^3	1.13cm^3	2.4cm^2	0.9 Kg/m	

Standart : 6000 mm

Ø28-1,7 mm Heavy Series Pipe Profile

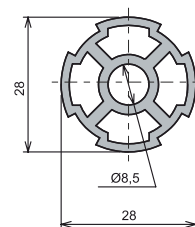
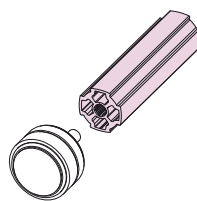

Code	Material	Moment of Inertia		Moment of Resistance		Area	Weight	
		I_x	I_y	W_x	W_y			
DK28-03A	6063	1.41cm^4	1.41cm^4	0.10cm^3	0.10cm^3	2.44cm^2	0.91 Kg/m	

Standart : 6000 mm

Ø28-1,7 mm L-Pipe Profile

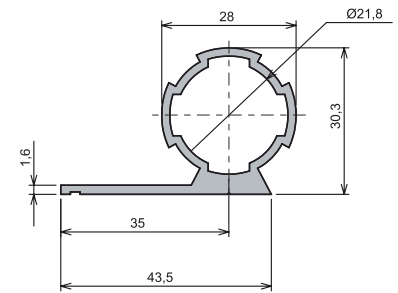
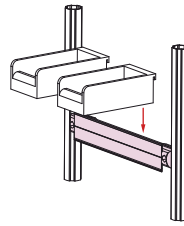

Code	Material	Moment of Inertia		Moment of Resistance		Area	Weight	
		I_x	I_y	W_x	W_y			
DK28-04A	6063	1.83cm^4	3.69cm^4	0.13cm^3	0.26cm^3	2.35cm^2	0.87 Kg/m	

Standart : 6000 mm

Ø28-1,7 mm T-Pipe Profile

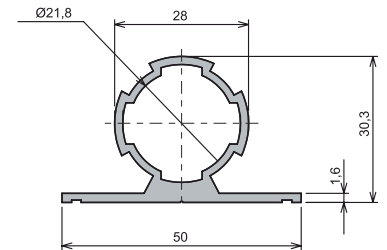
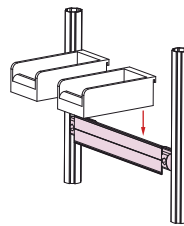

Code	Material	Moment of Inertia		Moment of Resistance		Area	Weight	
		I_x	I_y	W_x	W_y			
DK28-05A	6063	2.59cm^4	2.81cm^4	0.18cm^3	0.20cm^3	2.45cm^2	0.91 Kg/m	

Standart : 6000 mm

Ø28-1,7 mm Double Pipe Profile

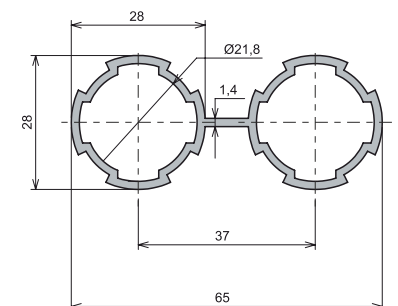
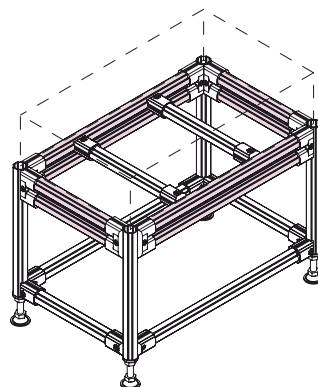

Code	Material	Moment of Inertia		Moment of Resistance		Area	Weight	
		I_x	I_y	W_x	W_y			
DK28-06A	6063	2.33cm^4	1.23cm^4	0.17cm^3	0.09cm^3	3.05cm^2	1.13 Kg/m	

Standart : 6000 mm

External Versatile Connectivity

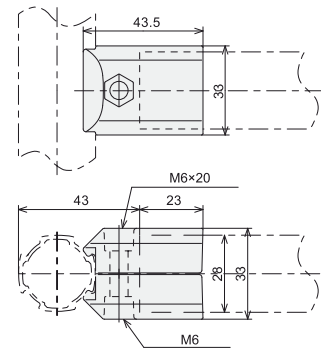
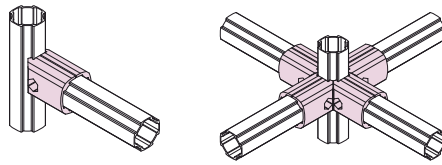

Code	DKJ-A01
Material	Cast Aluminium
Weight	52 Gr

Shear load (N)	760	Pulling load (N)	400	Carrying Capacity (N)		Length L (MM)	Carrying Capacity (N)	
				Vertical	Horizontal		Vertical	Horizontal
						100	105	52
						200	52	27
						300	35	17
						500	21	10
						Loading Moment (N*m)	10	5

Internal Versatile Connectivity

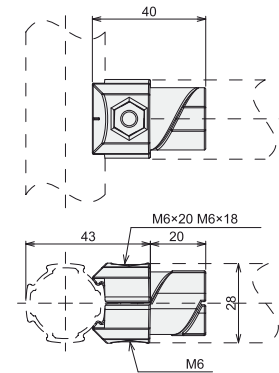
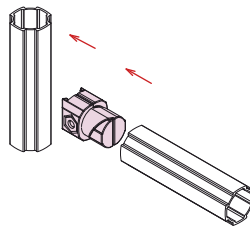

Code	DKJ28-B01
Material	Cast Aluminium
Weight	45 Gr

Shear load (N)	720	Pulling load (N)	400	Carrying Capacity (N)		Length L (MM)	Carrying Capacity (N)	
				Vertical	Horizontal		Vertical	Horizontal
						100	86	57
						200	43	29
						300	29	19
						500	17	11
						Loading Moment (N*m)	9	6

Swivel Connectivity

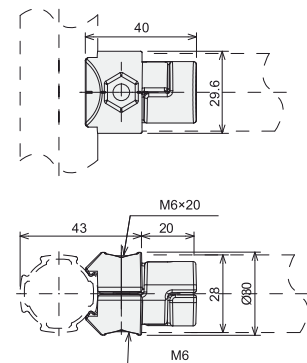
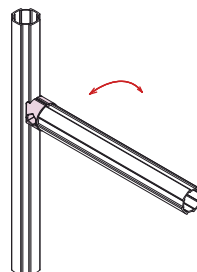

Code	DKJ28-B01D
Material	Cast Aluminium
Weight	43 Gr

Shear load (N)	760	Pulling load (N)	400	Carrying Capacity (N)		Length L (MM)	Carrying Capacity (N)	
				Vertical	Horizontal		Vertical	Horizontal
						100	86	57
						200	43	29
						300	29	19
						500	17	11
						Loading Moment (N*m)	9	6

Power all-around Connection-External

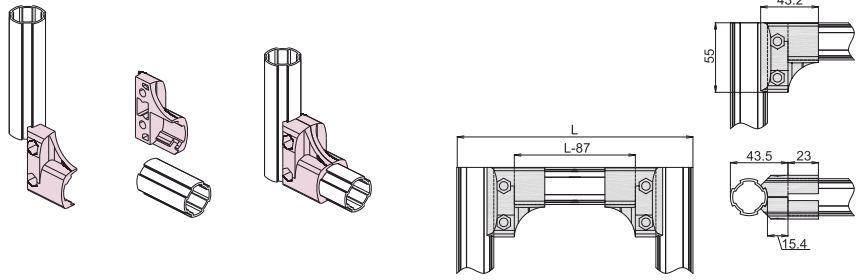

Code	Material	Weight
DKJ28-A01S	Cast Aluminium	90 Gr

Power all-around Connection-Internal

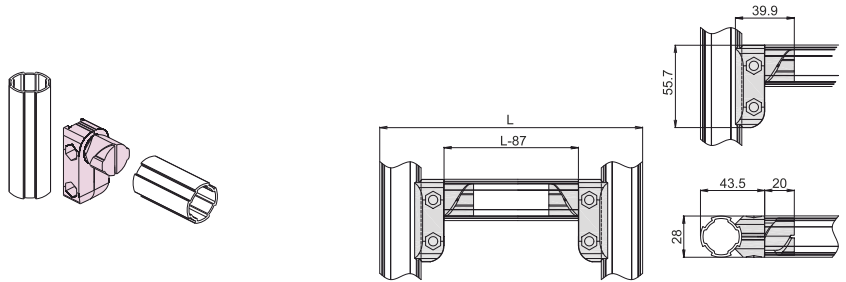

Code	Material	Weight
DKJ28-B01S	Cast Aluminium	85 Gr

Cross Connection

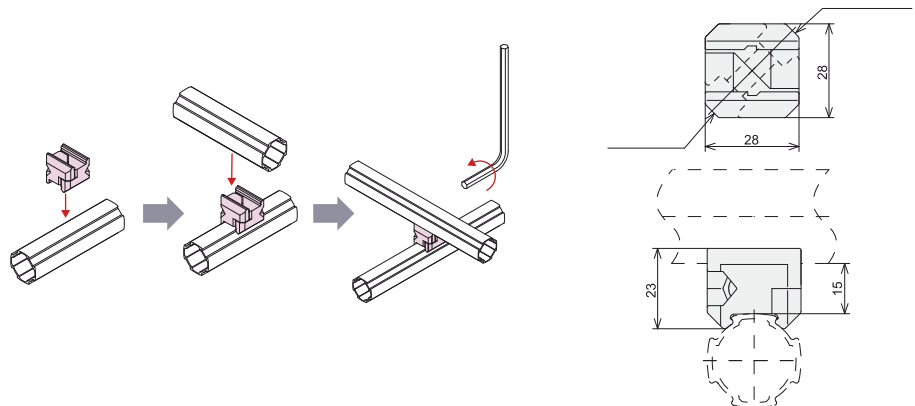

Code	DKJ28-A06
Material	Cast Aluminium
Weight	32 Gr

Max load (N)	755	Carrying Capacity (N)		Length L (MM)	(PC) (N)	
		Vertical	Horizontal			
			100	95	62	
			200	48	31	
			300	31	21	
			500	19	12	
Loading Moment (N*m)			10	6		

45° Connection-External

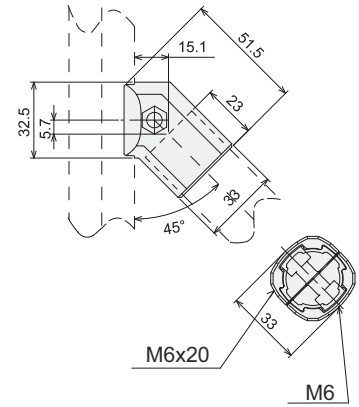
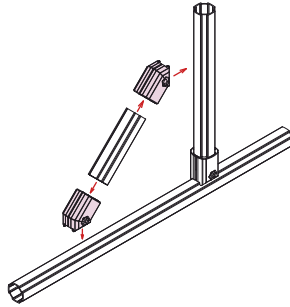

Code	DKJ28-A09
Material	Cast Aluminium
Weight	63 Gr

Shear load (N)	720	Pulling load (N)	400	Carrying Capacity (N)		Length L (MM)	Carrying Capacity (N)
				Vertical	Horizontal		
						100	157
						200	79
						300	52
						500	31
						Loading Moment (N*m)	16

45° Connection-Internal

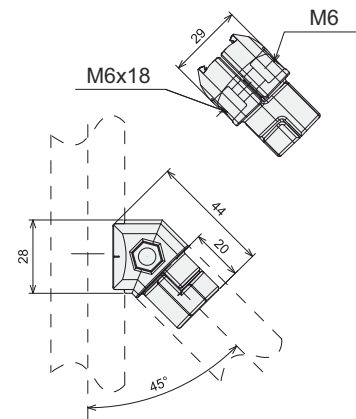
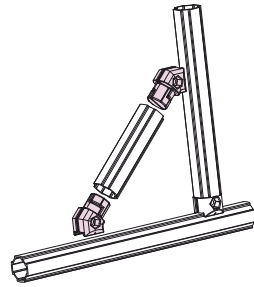

Code	DKJ28-B09
Material	Cast Aluminium
Weight	48 Gr

Shear load (N)	665	Pulling load (N)	247	Carrying Capacity (N)		Length L (MM)	Carrying Capacity (N)
				Horizontal			
						100	52
						200	27
						300	17
						500	10
						Loading Moment (N*m)	5

90° Connection-External

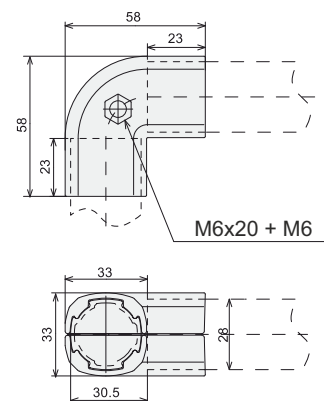
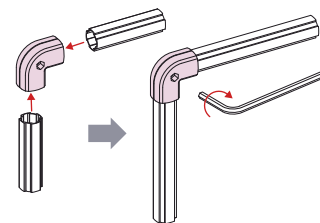

Code	DKJ28-A15
Material	Cast Aluminium
Weight	96 Gr

Pulling load (N)	200	Carrying Capacity (N)		Length L (MM)	Carrying Capacity (N)	
		Vertical	Horizontal		Vertical	Horizontal
				100	380	180
				200	190	95
				300	126	64
				500	76	38
				Loading Moment (N*m)	38	19

90° Connection-Internal

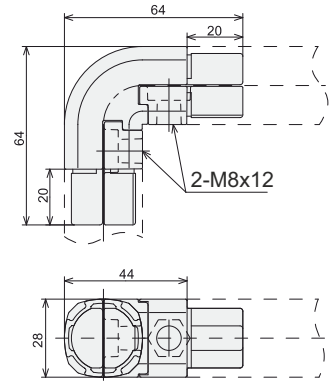
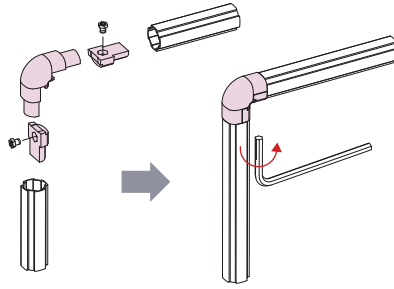

Code	DKJ28-B15
Material	Cast Aluminium
Weight	130 Gr

Max load (N)	420		Carrying Capacity (N)		Length L (MM)	Carrying Capacity (N)	
	Vertical	Horizontal	Vertical	Horizontal			
			100	124	62	62	
			200	62	31	31	
			300	41	21	21	
			500	25	12	12	
			12	6			

135° Connection-External

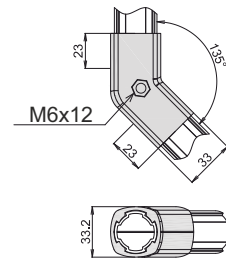
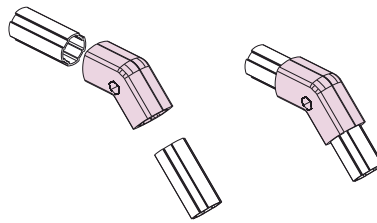

Code	Material	Weight
DKJ28-A03	Cast Aluminium	100 Gr

135° Connection-Internal

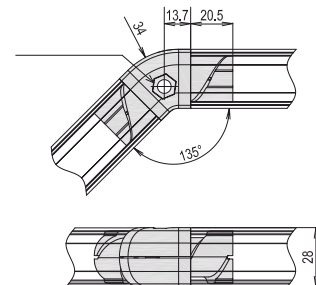
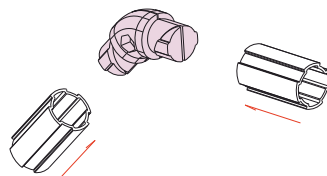

Code	Material	Weight
DKJ28-B03	Cast Aluminium	125 Gr

2-Way Connection

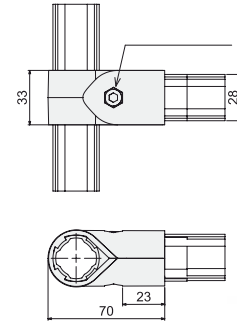
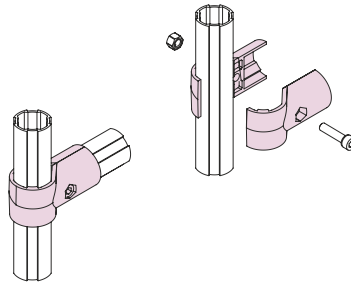

Code	Material	Weight	
DKJ28-C01	Cast Aluminium	91 Gr	

3-Way Connection

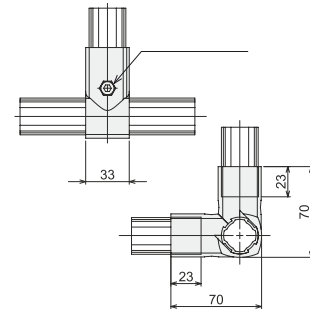
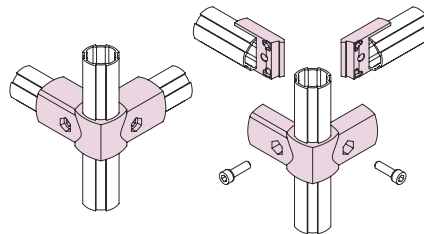

Code	Material	Weight	
DKJ28-C02	Cast Aluminium	127 Gr	

4-Way Connection

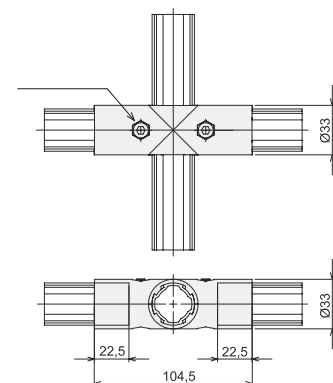
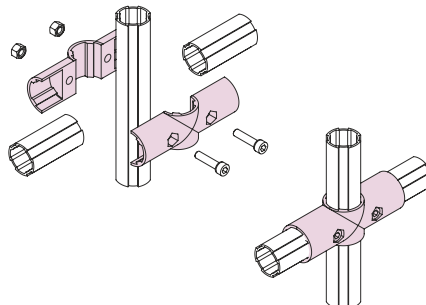

Code	Material	Weight	
DKJ28-C04	Cast Aluminium	130 Gr	

Versatile Dual Connection

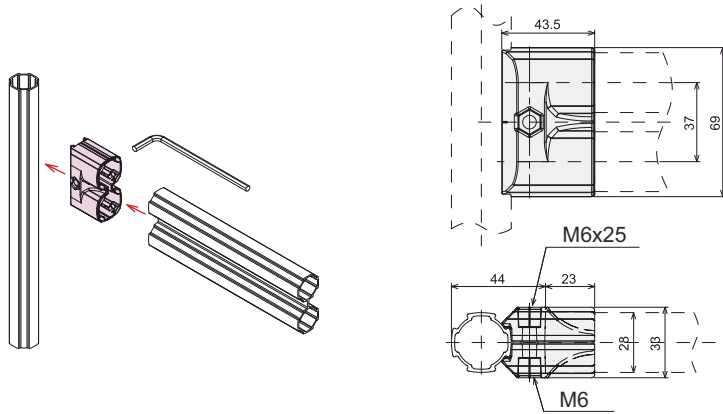

Code	DKJ28-A14
Material	Cast Aluminium
Weight	114 Gr

Shear load (N)	950	Pulling load (N)	428	Carrying Capacity (N)		Length L (MM)	Carrying Capacity (N)	
				Vertical	Horizontal		Vertical	Horizontal
						100	475	219
						200	238	109
						300	159	73
						500	95	44
						Loading Moment (N*m)	48	22

Corner Support Connection-Short

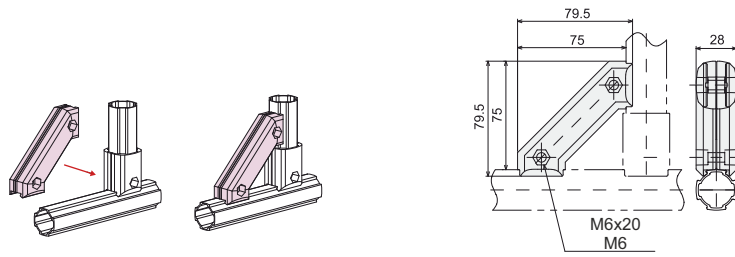

Code	DKJ28-A09D
Material	Cast Aluminium
Weight	96 Gr

Shear load (N)	755	Carrying Capacity (N)		Length L (MM)	Carrying Capacity (N)
		Diagonally			
				100	380
				200	190
				300	126
				500	76
				Loading Moment (N*m)	90

Corner Support Connection-Long

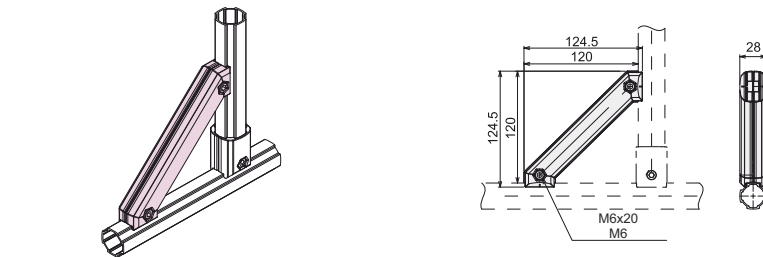

Code	DKJ28-A09E
Material	Cast Aluminium
Weight	176 Gr

Shear load (N)	755	Carrying Capacity (N)		Length L (MM)	Carrying Capacity (N)
		Diagonally			
				100	380
				200	190
				300	126
				500	76
				Loading Moment (N*m)	90

90° Angle Fitting-External

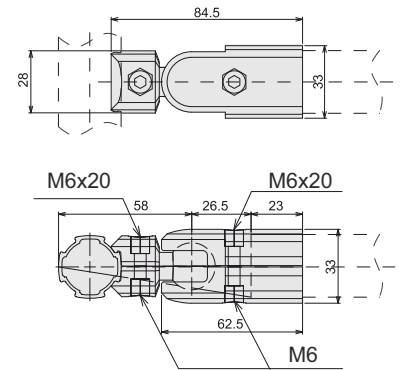
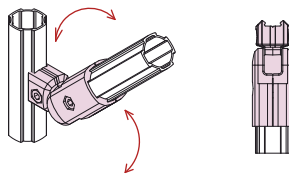

Code	DKJ-28-A07D
Material	Cast Aluminium
Weight	127 Gr

Max load (N)	250	Unit load	247
		Unit load	12

180° Angle Fitting-External

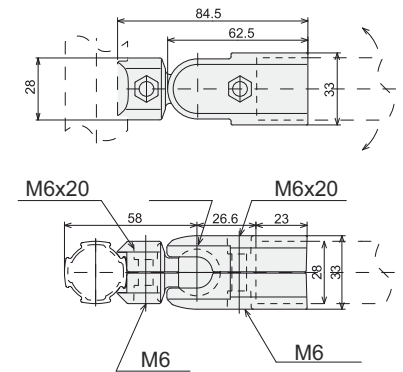
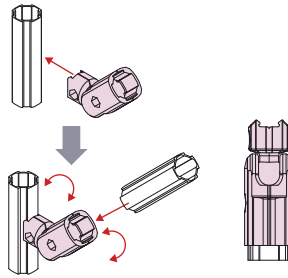

Code	DKJ-28-A07
Material	Cast Aluminium
Weight	121 Gr

Max load (N)	250	Unit load	247
		Unit load	12

180° Angle Fitting-Internal

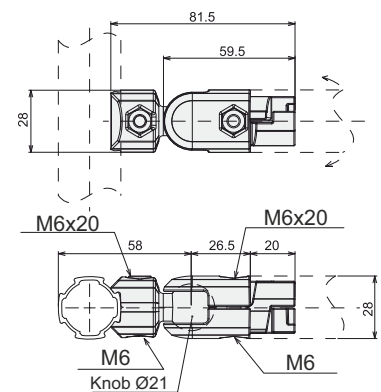
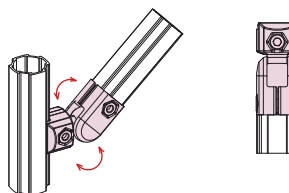

Code	DKJ28-B07
Material	Cast Aluminium
Weight	104 Gr

Max load (N)	760	Max load (N)	162

Extension Part-Internal

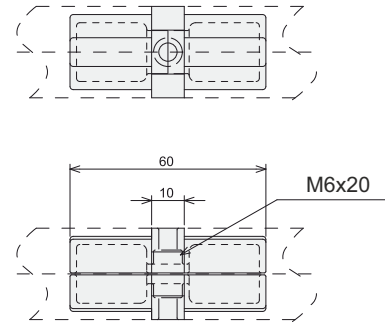
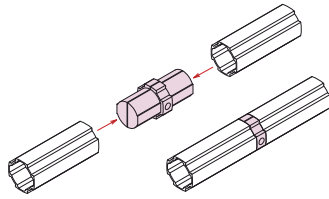

Code	DKJ28-B04
Material	Cast Aluminium
Weight	47 Gr

Shear load (N)	600	Carrying Capacity (N)		Length L (MM)	Carrying Capacity (N)	
		Vertical	Horizontal		Vertical	Horizontal
			100	124	760	
			200	62	380	
			300	41	254	
			500	25	152	
Loading Moment (N*m)				12	76	

Bridge Connection

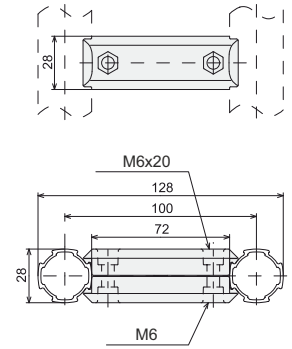
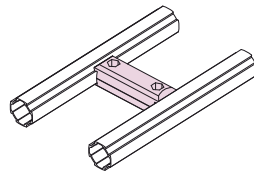

Code	DKJ28-A08
Material	Cast Aluminium
Weight	89 Gr

Max load (N)	855	Max load	171	Max	133	Burden Direction	Length L (MM)	(PC) (N)
		Unit load	15.2	load	12			
							100	81
							200	41
							300	27
							500	16
Loading Moment (N*m)							8	

Ground Fitting

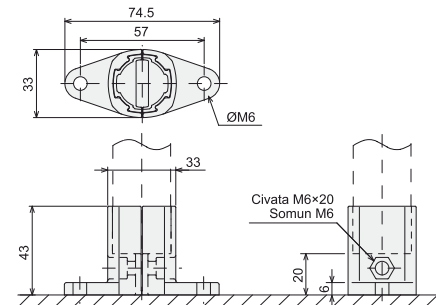
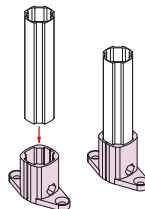

Code	Material	Weight
DKJ28-A17	Cast Aluminium	79 Gr

Parallel Connector

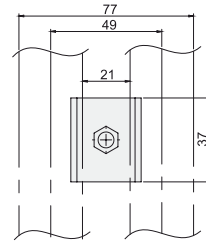
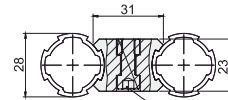
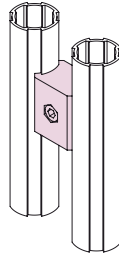

Code	DKJ28-A10
Material	Cast Aluminium
Weight	51 Gr

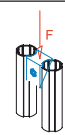
Drawing load (N)	258
	

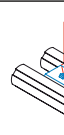
Drawing load (N)	380
Drawing load (N)	7
	

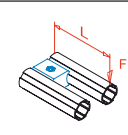
Burden Direction	Diagonally
	

Length L (MM)	Carrying Capacity (N)
100	81
200	41
300	27
500	16
Loading Moment (N*m)	8



Parallel Connector Armful

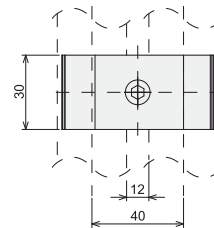
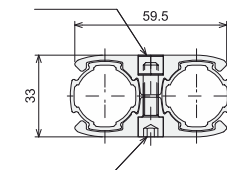
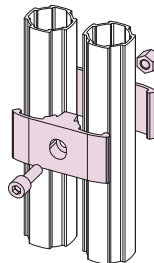

Code	DKJ28-A11
Material	Cast Aluminium
Weight	73 Gr

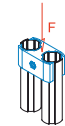
Drawing load (N)	912
	

Max load (N)	475
	

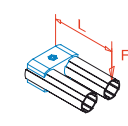
Burden Direction	Diagonally
	

Length L (MM)	Carrying Capacity (N)
100	177
200	86
300	57
500	34
Loading Moment (N*m)	17

90° Corner Connection

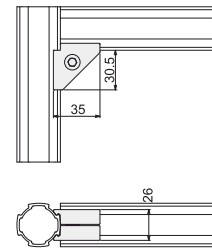
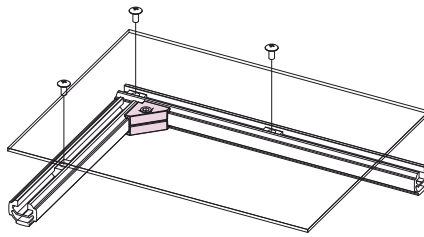

Code	Material	Weight	
DKJ28-A19	Cast Aluminium	45 Gr	

Channel Connection

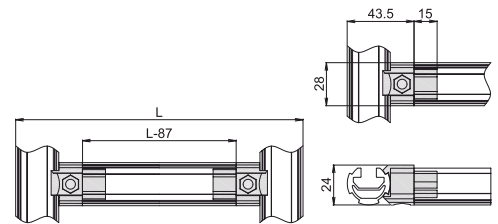
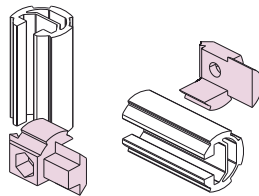

Code	Material	Weight	
DKJ28-B05	Cast Aluminium	45 Gr	

Handle Forming Connection

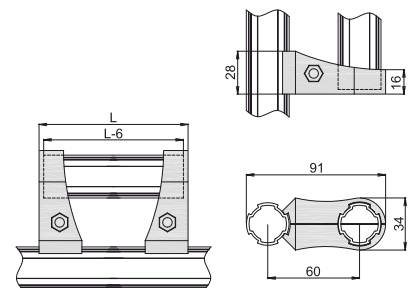
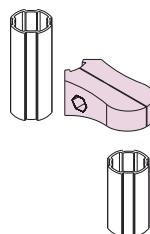

Code	Material	Weight	
DKJ28-A16	Cast Aluminium	80 Gr	

Mounting Bracket Single Axis Fit Long

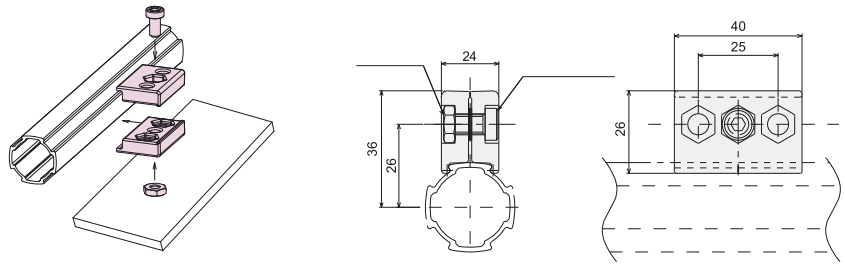

Code	DKJ28-A13
Material	Cast Aluminium
Weight	57 Gr

Max load (N)	390	Unit load	475
		Unit load	6

Mounting Bracket Single Axis Fit Short

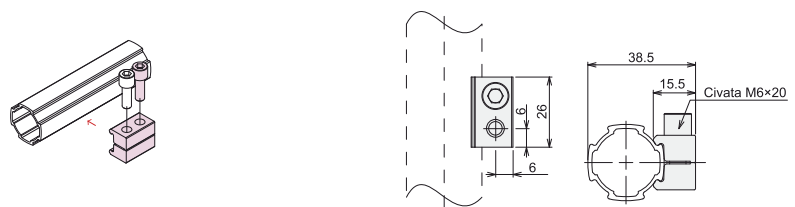

Code	Material	Weight	
DKJ28-A20	Cast Aluminium	23 Gr	

Mounting Bracket Double Axis Fit

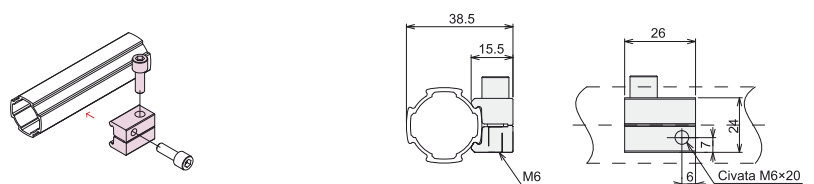

Code	Material	Weight	
DKJ28-A21	Cast Aluminium	25 Gr	

Hanger Knob

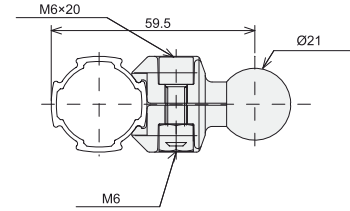
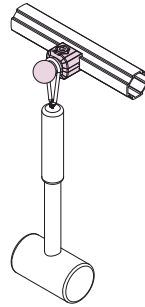
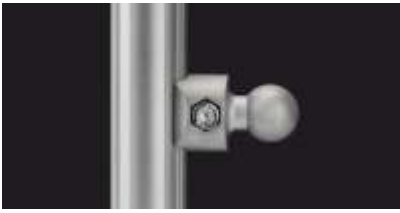

Code	Material	Weight	
DKJ28-A18	Cast Aluminium	42 Gr	

Knuckle-Pin Connection

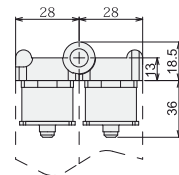
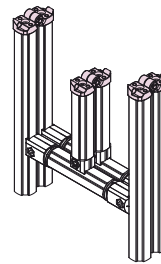
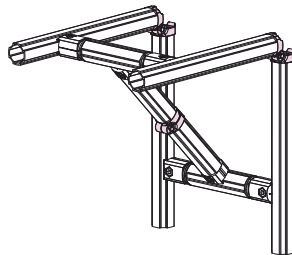

Code	DKE28-07
Material	Cast Aluminium
Weight	118 Gr
Τιμή/τμχ	

Unit load (N)	9

Knuckle Connection

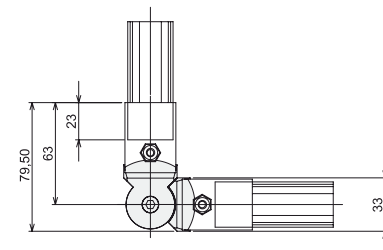
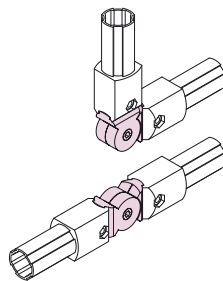

Code	Material	Weight	
DKE28-10	Cast Aluminium	68 Gr	

Rotating Fitting

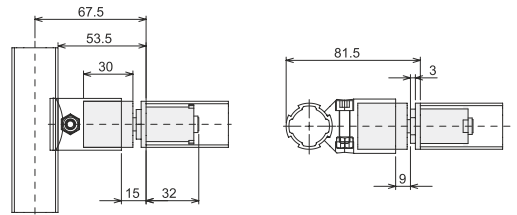
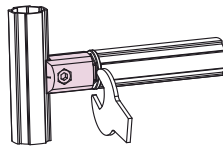

Code	Material	Weight	
DKE28-08	Cast Aluminium	78 Gr	

Pipe Profile Cover

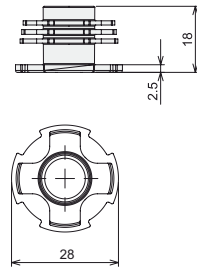
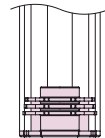

Code	Material	Weight	
DKP28-01	Polypropylene	2 Gr	

Channel Profile Cover

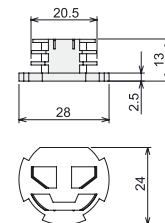
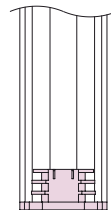

Code	Material	Weight	
DKP28-03	Polypropylene	2 Gr	

Foot Plastic

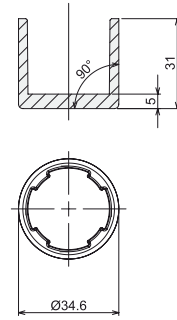
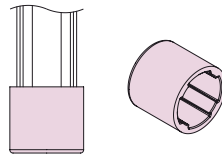

Code	Material	Weight	
DKP28-04	Polypropylene	8 Gr	

Foot Bracket Plastic

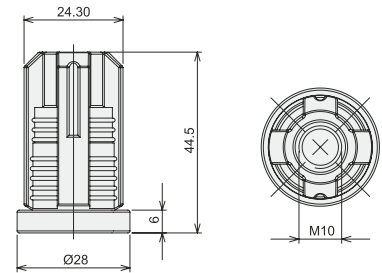
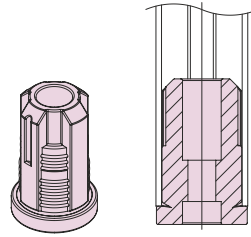

Code	Material	Weight	
DKP28-10	Polypropylene	28 Gr	

Foot Bracket Metal

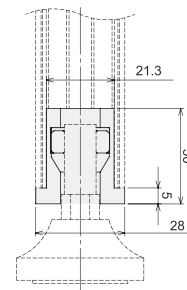
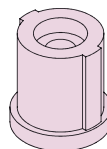

Code	Material	Weight	
DKE28-17	Cast Aluminium	114 Gr	

Plate Fastening Part

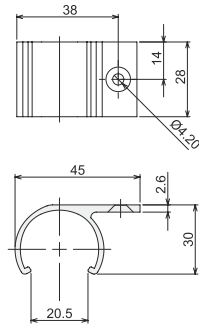
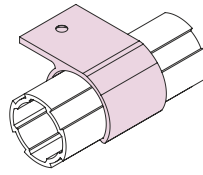

Code	Material	Weight	
DKE28-01	Cast Aluminium	14 Gr	

Plate Fixing Bracket Holder

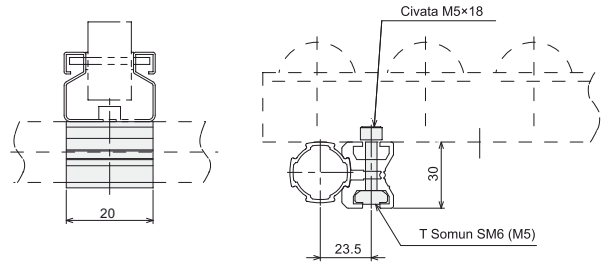
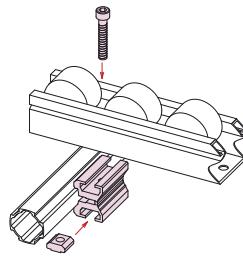

Code	DKE28-05
Material	Cast Aluminium
Weight	27 Gr

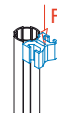
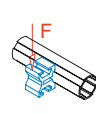
	250	247
		12
		

Hinge Metal

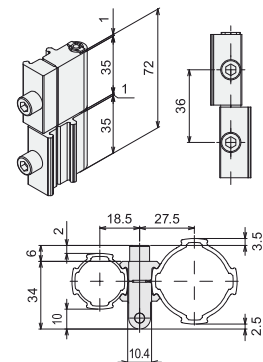
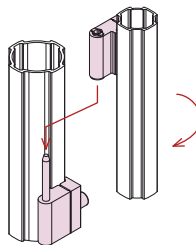

Code	Material	Weight	
DKE28-27L	Cast Aluminium	86 Gr	
DKE28-27R	Cast Aluminium	86 Gr	

Positioning Ring Horizontal

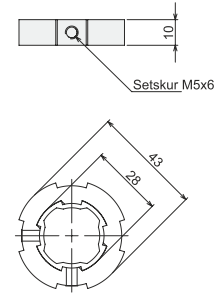
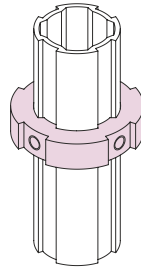

Code	Material	Weight	
DKE28-03	Cast Aluminium	17 Gr	

Positioning Ring Vertical

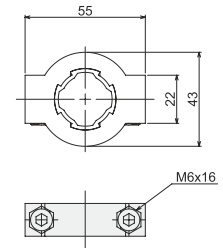
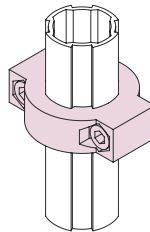

Code	Material	Weight	
DKE28-04	Cast Aluminium	54 Gr	

One-Way Stopper

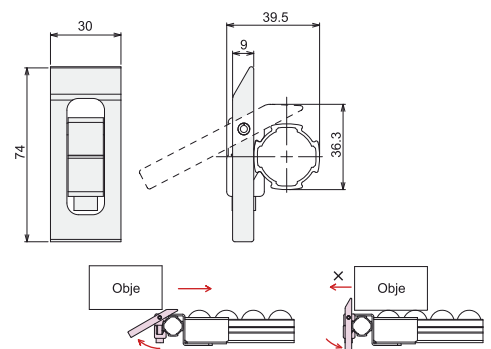
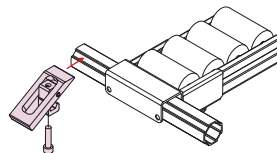

Code	Material	Weight	
DKE28-29	Cast Aluminium	52 Gr	

Rotatable Slide Connector 53 mm

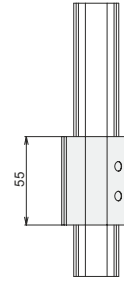
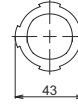
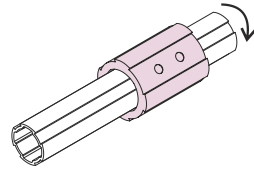

Code	Material	Weight	
DKE28-L55Z	6065T6+Polypropylene	48 Gr	

Slide Connector 55 mm

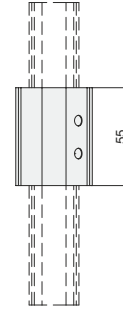
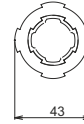
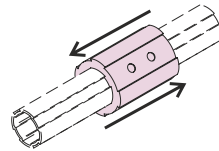

Code	Material	Weight	
DKE28-L55D	6065T6+Polypropylene	46 Gr	

Counter Weights

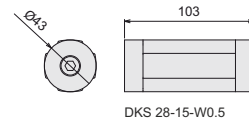
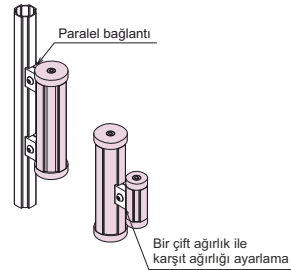

DKS 28-15-W0.5

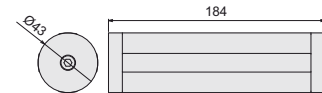

DKS 28-15-W1

Code	Material	Weight	
DKS 28-15-W0.5	6065T6+Carbon Steel	500 Gr	
DKS 28-15-W1	6065T6+Carbon Steel	1000 Gr	

Rotary Connector

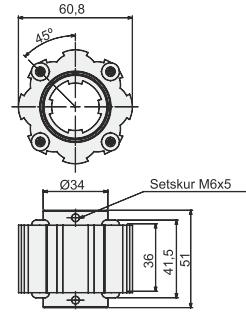
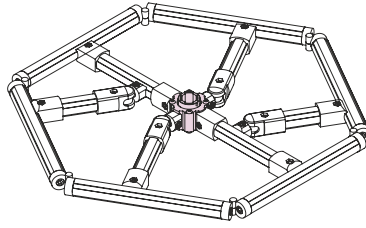

Code	Material	Weight	
DKE28-12	6065T6+Polypropylene	208 Gr	

Locked Rotary Connector

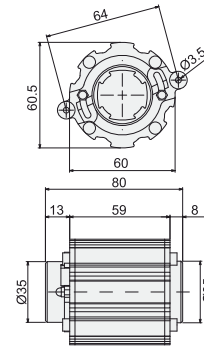
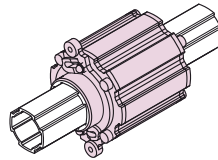

Code	Material	Weight	
DKE28-31	6065T6+Polypropylene+Carbon Steel	345 Gr	

Height Adjuster

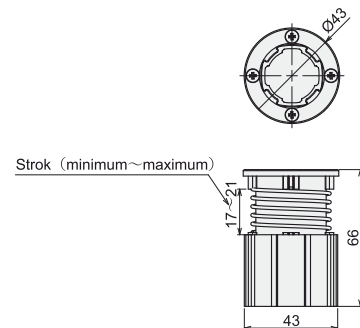
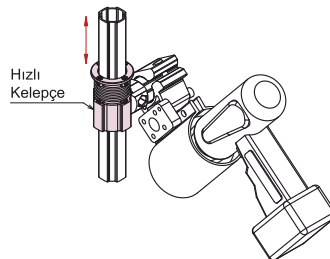

Code	Material	Weight	
DKE28-30	6065T6+Carbon Steel	99 Gr	

Ø28 Hydraulic Damper Stroke

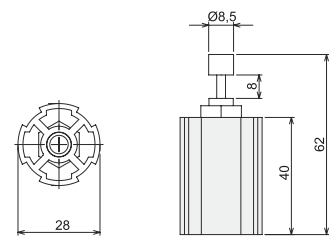
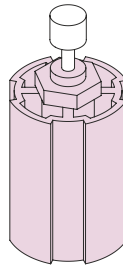

Code	Material	Weight	
DKE28-26	6065-T6+Carbon steel	40 Gr	

Vertical Lift Lock

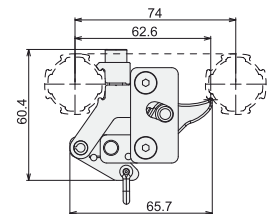
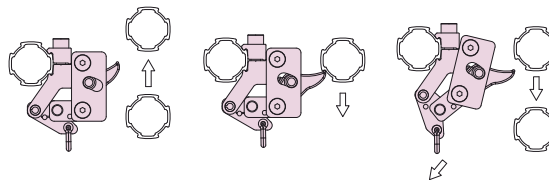

Code	Material	Weight	
DKE28-35	6065-T6+Polypropylene+Carbon steel	130 Gr	

Floor Braking Lift

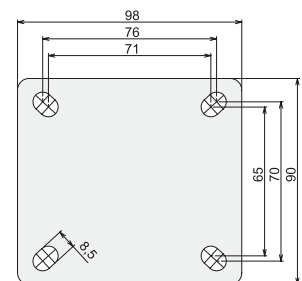
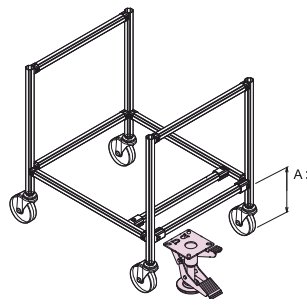

Code	Material	Weight	
DKE28-36-4	DKP	1400 Gr	

Ø28 Caster Support 30x70

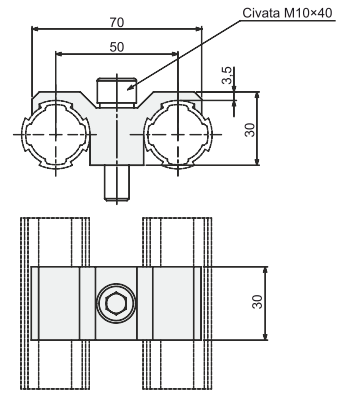
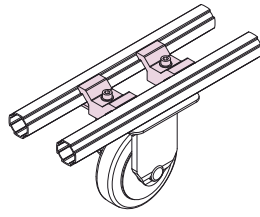

Code	Material	Weight	
DKE28-02	Cast Aluminium	84 Gr	

Foot Pedal

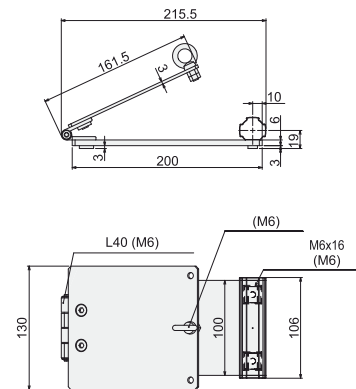
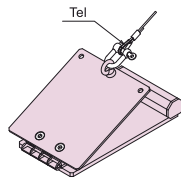

Code	Material	Weight	
DKE28-37	Cast Aluminium	688 Gr	



U Groove Plastic Pulley Ø30

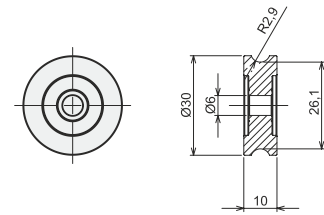
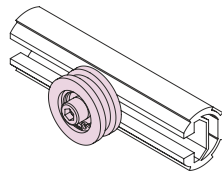

Code	Material	Weight	
DKE28-17	Polypropylene+Carbon steel	12 Gr	

V Groove Metal Pulley Ø33

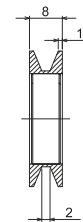
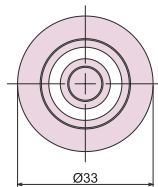

Code	Material	Weight	
DKE28-18	Carbon steel	30 Gr	

U Groove Plastic Pulley Ø38

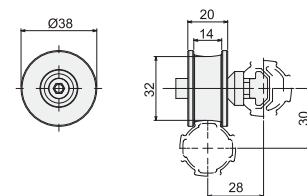
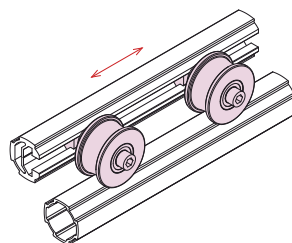

Code	Material	Weight	
DKZ28-Z09	Carbon steel+Derlin	63 Gr	

Slide Roller E 28

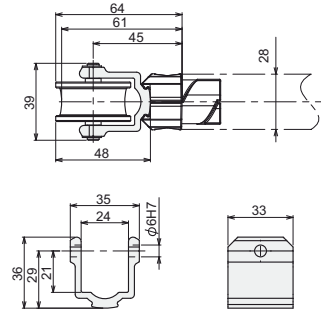
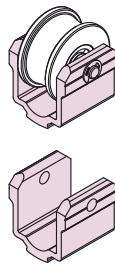

Code	Material	Weight	
DKE28-28	6065T6+Delrin	66 Gr	

Slide Roller Z 28/10

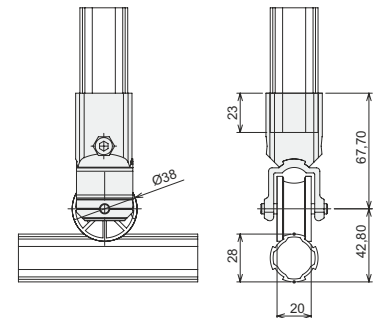
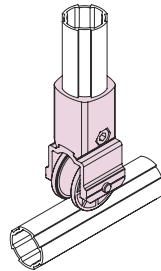

Code	Material	Weight	
DKZ28-Z10	6065T6+Delrin	69 Gr	

Slider Wheel

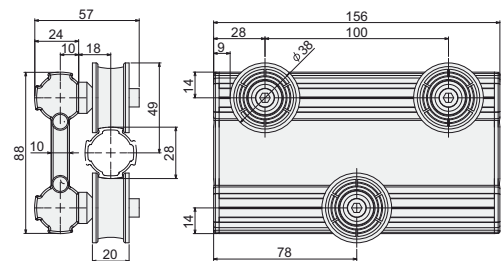
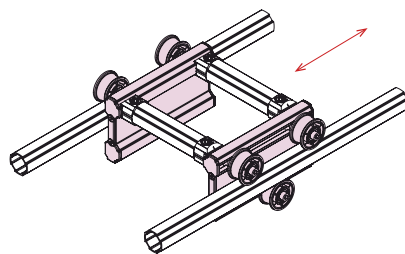

Code	Material	Weight	
DKE28-38	6065T6+Delrin	460 Gr	

Ø28 Linear Slider 100 mm

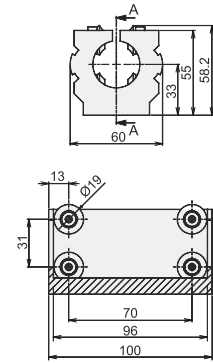
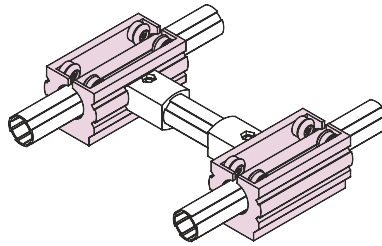

Code	Material	Weight	
DKE28-13-L100	6065-T6+Polypropylene+Carbon steel	243 Gr	

Ø28 Wear Plastic

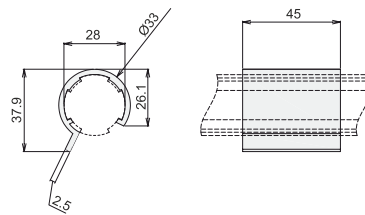

Code	Material	Weight	
DKL40-03	Polypropylene	1.6 Gr	

Ø28 Hangtag Clip

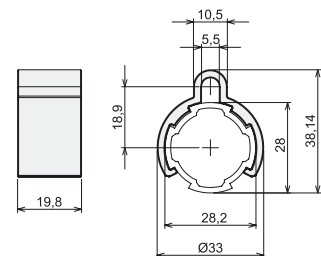
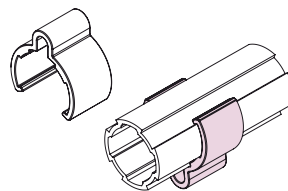

Code	Material	Weight	
DKP28-05	Polypropylene	3 Gr	

Plastic-Coated Stainless Steel Rope



Code	Material	Weight	MM
DKE28-19	Stainless steel	12 Gr/Mt	4-5-6-8

Rope Connection Clip

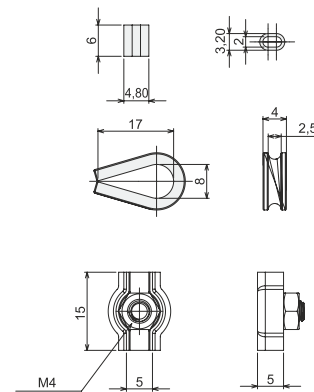

Code	Material	Weight
DKE28-20	Carbon steel	5 Gr

Rope Positioning Part

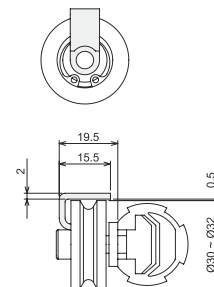
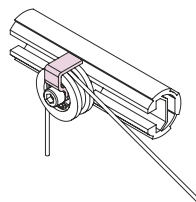

Code	Material	Weight
DKE28-24	Carbon steel	5 Gr

Ring Bolt

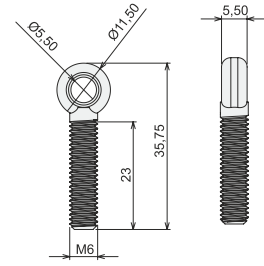
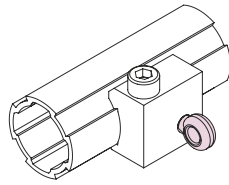

Code	Material	Weight	
DKE28-21	Stainless steel	5 Gr	

Ring Bolt

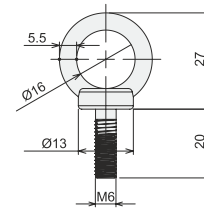
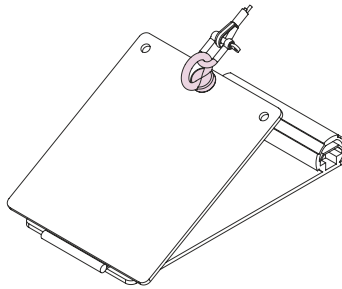

Code	Material	Weight	
DKE28-23	Stainless steel	19 Gr	

Type-D Ring Hanger

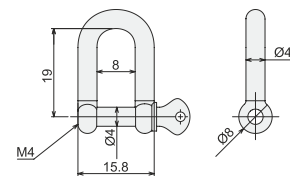
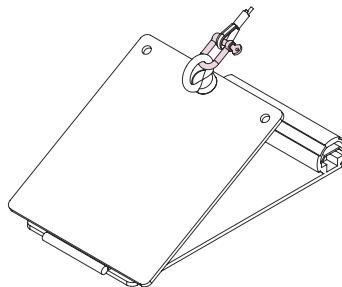

Code	Material	Weight	
DKE28-22	Stainless steel	7 Gr	

Roller Rail

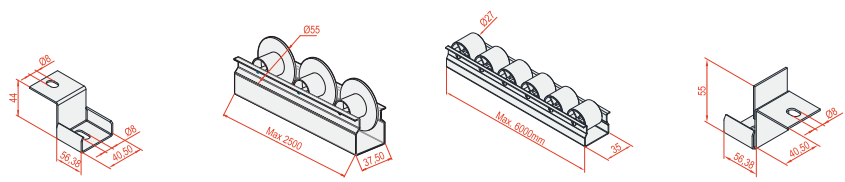
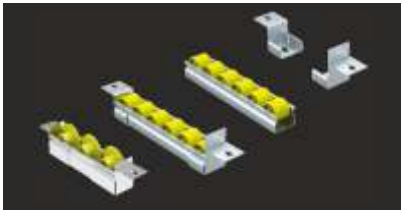

Code	Product	Material	Weight	Meter
RR 35	Roller Track 37 mm-Ø 27	Body DKP-Plastic Reel	959 Gr/Mt.	6,00 m
RS 37	Roller Track Side Support 37 mm-Ø 27	Body DKP-Plastic Reel	1000 Gr/Mt.	2,50 m

Retractable Spring

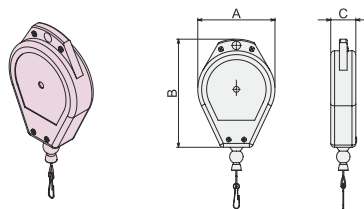

Code	Product	Material	Weight
BRS 15	Spring Balancer-Retractable Spring 0,6-1,5 kg	Spring Steel	600 Gr
BRS 30	Spring Balancer-Retractable Spring 1,5-3,0 kg	Spring Steel	600 Gr
BRS 50	Spring Balancer-Retractable Spring 3,0-5,0 kg	Spring Steel	850 Gr

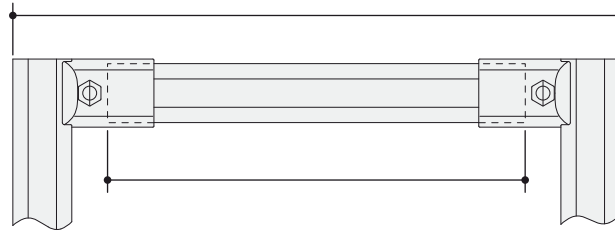

Outer	Inner
<p>Section A-A</p> <p>$L = A - (43,5 \times 2)$</p>	<p>Section A-A</p> <p>$L = A - (43 \times 2)$</p>
<p>Section A-A SCALE 1:2.5</p> <p>$L = A - (32,5 \times 2)$</p>	<p>Section A-A SCALE 1:2.5</p> <p>$L = A - (44 \times 2)$</p>
<p>$L = \sqrt{(X-30)^2 + (Y-30)^2} - 26,64 \times 2$</p>	<p>$L = \sqrt{(X-30)^2 + (Y-30)^2} - 26,5 \times 2$</p>
<p>$L = \sqrt{(X^2 + X^2)} - 26,76 \times 2$</p>	<p>$L = \sqrt{(X^2 + X^2)} - 21,91 \times 2$</p>



MEIMARIDIS
BROS



TOOLS
LAND

Παρατηρήσεις

- Στις παραπάνω τιμές δεν περιλαμβάνεται ο Φ.Π.Α.
- Τρόπος πληρωμής μετρητοίς
- Τα μεταφορικά επιβαρύνουν τον πελάτη
- Ο παρών τιμοκατάλογος καταργεί τον προηγούμενο
- Στα προφίλ δεν γίνονται επιστροφές
- Στα εξαρτήματα οι επιστροφές θα γίνονται κατόπιν συνεννόησης
- Χρόνος παράδοσης κατόπιν συνεννόησης
- Η εταιρία δεν φέρει καμία ευθύνη για τυχόν φθορές από την μεταφορά

ΑΡΙΘΜΟΣ ΛΟΓΑΡΙΑΣΜΟΥ ΤΡΑΠΕΖΑ ΠΕΙΡΑΙΩΣ:

Αρ. λογ.: 5242 0035 75529

IBAN: GR 22017 22420 00524 20035 75529

Σημειώσεις





ΕΜΠΟΡΙΑ ΣΙΔΗΡΟΥ - ΑΛΟΥΜΙΝΙΟΥ - ΓΥΨΟΣΑΝΙΔΑΣ - ΧΡΩΜΑΤΩΝ
ΣΟΒΑΔΩΝ - ΙΝΟΧ ΠΑΝΤΟΣ ΤΥΠΟΥ - ΒΙΟΜΗΧΑΝΙΚΑ ΕΡΓΑΛΕΙΑ
(ΣΤΡΑΝΤΖΑ - ΨΑΛΙΔΙ - ΚΥΛΙΝΔΡΟΣ - ΠΑΝΤΟΓΡΑΦΟΣ)

ΑΦΟΙ ΜΕΪΜΑΡΙΔΗ Ο.Ε.

Σταδίου 97 - Βέροια

Τηλ.: 23310 23342 - 23178 / Fax: 23310 67869

www.meimaridis.gr | info@meimaridis.gr

STANLEY



KNAUF



ALUMINCO
ALUMINIUM BUILDING SYSTEMS

KRAFT
paints



20266

e-mail: sales@aluminium-profile.gr

www.aluminium-profile.gr